



99030/99140/99065



99031/99159

Universal Gas Detector

ITEM#99030-Local Mounted-Incl Domestic Power Supply

ITEM#99140-Local Mounted-Incl Int'l Power Supply

ITEM#99065-Local Mounted. No Horn. No Power Supply

ITEM#99031-Remote Cable-Incl Domestic Power Supply

ITEM#99159-Remote Cable-Incl Int'l Power Supply

Product Summary

The PureAir Universal Gas Detector is ideal for facilities requiring continuous monitoring of toxic and corrosive gases. The transmitter is designed to be connected to a dedicated, renewable gas sensor which is programmed for a specific type of gas in parts-per-million (ppm). This gas detector is well suited for environments such as laboratories, hospitals, food refrigeration, pharmaceutical manufacturers and, for any industry applications where toxic, corrosive gases including, but not limited to, ammonia, HF, hydrogen, HCL, bromine, chlorine, sulfur dioxide are used. PureAir's renewable, long-life sensors will last up to 8 years in a normal environment and can easily be recharged with electrolyte on the user's own site.

Facilities That Need This Product

- *Pharmaceutical*
- *Hospitals*
- *Cleanrooms*
- *Laboratories*
- *Refrigeration*
- *Semiconductor*

FEATURES

- Transmitter connects to any PureAir toxic or corrosive gas sensor
- Plug & play sensor sets the transmitter gas & measurement range
- Dual level user adjustable alarm relays
- 4-20m A analog output (Active)
- Built-in horn (99030,99140,99031,99159)
- Visual alarm LEDs
- Electronics continuously check sensor & system status
- Low-cost, long-life renewable sensor
- Quick, easy sensor calibration
- Optional remote cable for monitoring up to 30 feet from the transmitter (99031, 99159)
- Connects to PLC or SCADA controller
- 24V DC Power supply included (99030,99031)
- International Power Supply Included (99140, 99159)



Why choose PureAir?

PureAir Monitoring Systems, Inc. is a leader in oxygen monitoring and gas detection. For over 20 years, we have dedicated ourselves to the safety of our clients, and the customers they serve, by manufacturing monitors that are long-lasting, accurate, and reliable. PureAir takes pride in providing exceptional customer service, along with 24/7 availability to our technical service department.

Why a Universal Gas Detector?

PureAir's Universal Gas Detector is designed for continuous monitoring where low ppm toxic, corrosive gases are used and pose a hazard to personnel.

What gases can be detected with an Universal Gas Detector?

PureAir's Universal Gas Detector continuously measures levels of toxic, corrosive gases such as, ammonia, chlorine, bromine, HCL, and hydrogen, among others.

Easy to Use

Secure the transmitter to the wall so that the display is easily visible, plug in the sensor cell, and connect to 24V DC power source. The optional remote cable allows for gas monitoring up to 30 feet from the transmitter. The monitor will begin measuring gas levels after a brief startup period. Gas levels are displayed clearly on the screen for easy access and visibility.

Top Advantages of Universal Gas Detectors



Universal Gas Detector

PureAire's Universal Gas Detector comes with 2 adjustable alarm setpoints that can connect to a horn/strobe, exhaust fan, 8 channel controller, remote display, or into building systems. Alarm signals also can tie into automatic shut-off valves when gas levels pose a hazard to personnel.



Easy To Use

The Universal Gas Detector provides constant monitoring with little to no adjustments, saving you time and money while allowing the monitor to operate seamlessly. Our renewable, long-life sensors can be easily recharged on the users' own site.

99030/99140/99065

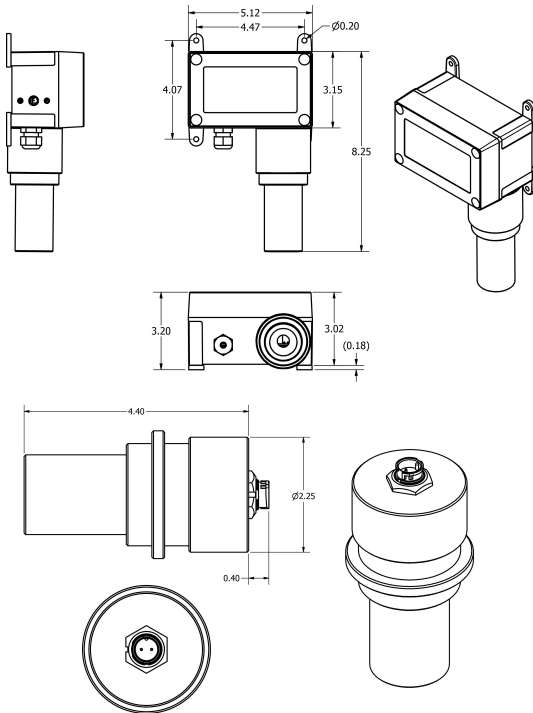

99031/99159

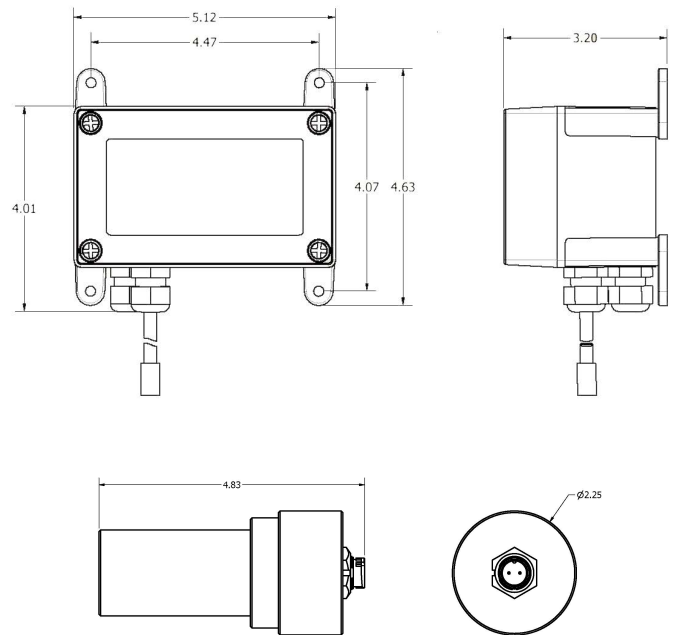

Top Accessories



**8 Channel Programmable
Controller for O2 or Gas
Monitors**

ITEM #: 99196



**Remote Digital
Display**

ITEM #: 99091



Red Horn/Strobe

ITEM #: 42002



1-888-788-8050

info@pureaire.net
pureairemonitoring.com

1140 Ensell Road
Lake Zurich, IL 60047
1-847-726-6000